



**PRO-CUT INTERNATIONAL**

**800.543.6618**



**PFM 9.0** **TECHNICAL MANUAL**  
**ON-CAR BRAKE LATHE**

## Our Mission

---

**Pro-Cut International** is dedicated to providing our customers with the most advanced, precise, and profitable tools for brake repair. We have worked with, learned from, and solved problems for people at all levels of the brake repair business — from the largest auto manufacturers and national service chains to one-bay, one-man operations. It is a business our entire staff lives, eats, and breathes. We welcome you to our table and look forward to working with you to improve your brake service business.



## Safety and Warning Information

---

**The PFM 9.0 SmartLathe** is a precision instrument which requires close attention while in operation. It will provide many years of service if it is operated safely. Safety is everyone's responsibility. Therefore, **before** assembling or operating this lathe, you must do the following:

- 1) Read and understand the owner's manual in its entirety.
- 2) Always wear protective eyewear when operating the lathe. Small particles produced during rotor cutting can cause severe damage to the eyes.
- 3) Never wear loose-fitting clothing while operating the lathe. The lathe contains moving parts which could catch or grab clothing that is not secure.
- 4) Keep hands away from moving parts during operation.
- 5) Keep body parts free of electrical connections. This lathe runs by electricity. As with all electrical equipment, care must be taken to avoid shocks and other electrical injury.

# Contents

---

iv	<b>Introduction</b>
1	<b>Addressing and Solving Customer Brake Concerns</b>
2	<b>PFM 9.0 Lathe Overview</b>
3	<b>Setting Up a New Lathe</b>
4	<b>Vehicle Preparation</b>
5	<b>Where to Start - Driver or Passenger Side?</b>
6	<b>Lathe Preparation</b>
7	<b>Machining Rotors: The 4/9.0 Solution</b>
	Step 1: Mount the Adapter
	Step 2: Set Up the Lathe
	Step 3: Adjust for Lateral Runout
	Step 4: Make the Cut
13	<b>Machining the Opposite Side</b>
14	<b>Vehicle Reassembly</b>
14	<b>Maintenance</b>
15	<b>Troubleshooting: Assuring a Smooth Finish</b>
18	<b>Troubleshooting: Lateral Runout Adjustment</b>
19	<b>Reading the Binary Codes</b>
20	<b>Adapter Guide</b>
21	<b>PFM 9.0 Parts Diagram</b>



**PRO-CUT backs every lathe and product we manufacture and distribute.** Your PFM 9.0 on-car lathe is covered under Pro-Cut's **Same Day Parts Promise**. If you have any problem with your PFM 9.0 lathe, simply call Pro-Cut toll-free (800.543.6618) before 3:00 p.m. Eastern Standard Time, and we'll diagnose the problem and have the parts out to you that afternoon — or the parts are FREE.

---

## Introduction

---



The PFM 9.0 on-car brake lathe.

Congratulations on your purchase of the **PRO-CUT PFM 9.0**, the world's fastest and most accurate computerized on-car brake lathe.

For many years, on-car lathes were used only for rotors that were difficult to remove. Due to current trends, virtually all auto manufacturers now require or recommend the use of on-car technology. By matching a rotor to the hub, the PFM 9.0 achieves superior accuracy with breathtaking speed. There is simply no better way to resurface a rotor than with the patented PFM 9.0.

The following pages are designed to guide you through setup, operation, and maintenance of your lathe. We also recommend that you view the enclosed PFM 9.0 training video.

Also enclosed in the Resource Kit binder is your PFM 9.0 warranty activation card. Please take a moment to fill out the form and send or fax it back to us so we can register you for your 12-month warranty.

If you have any questions along the way, please call us. Our technical support team is standing by from 8 a.m. to 5 p.m. Eastern time. Or browse our website for technical information and tips: [www.procutinternational.com](http://www.procutinternational.com).

**Welcome to the Pro-Cut Team!**



## Addressing and Solving Customer Brake Concerns

Runout in the rotor leads to thickness variation. Thickness variation is felt as brake pedal pulsation. It is this pulsation that results in a customer complaint. Pro-Cut matches the rotor to the hub, thereby eliminating runout, the root cause of pulsation.

- **LATERAL RUNOUT leads to ...**
  - **THICKNESS VARIATION which results in ...**
    - **BRAKE PEDAL PULSATION**

Brake pedal pulsation is most often the result of **thickness variation** in the brake rotor. Thickness variation is the technical term for a rotor that is not uniformly thick. New rotors are uniformly thick, and stop the vehicle smoothly. But thickness variation can develop over time and eventually lead to brake pedal pulsation.

How does thickness variation develop? Through **lateral runout** in the face of the rotor. Lateral runout is the technical term for “wobble,” and is a measurement of how much the surface of the disc wobbles from side to side as it rotates. A rotor with lateral runout will not wear evenly, and distortion increases over time. As the vehicle moves down the road with the brakes relaxed, the rotor will brush each pad once per revolution, resulting in a thin spot on the rotor.

Since vehicle hubs often have lateral runout due to stacked component tolerances, a new or newly machined rotor will often exhibit excessive lateral runout as it turns on the hub. Most manufacturers require rotor runout to be below 0.003".

The PFM 9.0 allows you to match every rotor to the hub on which it turns. The on-board computer delivers a precise alignment between the lathe axis and the hub axis, thereby guaranteeing that a Pro-Cut machined rotor will have less than 0.002" lateral runout every time.

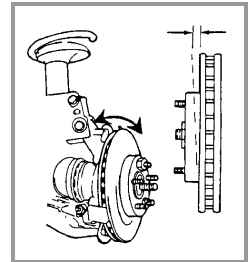

By machining the rotor to match the hub assembly on which it sits, lateral runout can be eliminated.



## **PFM 9.0 Lathe Overview**

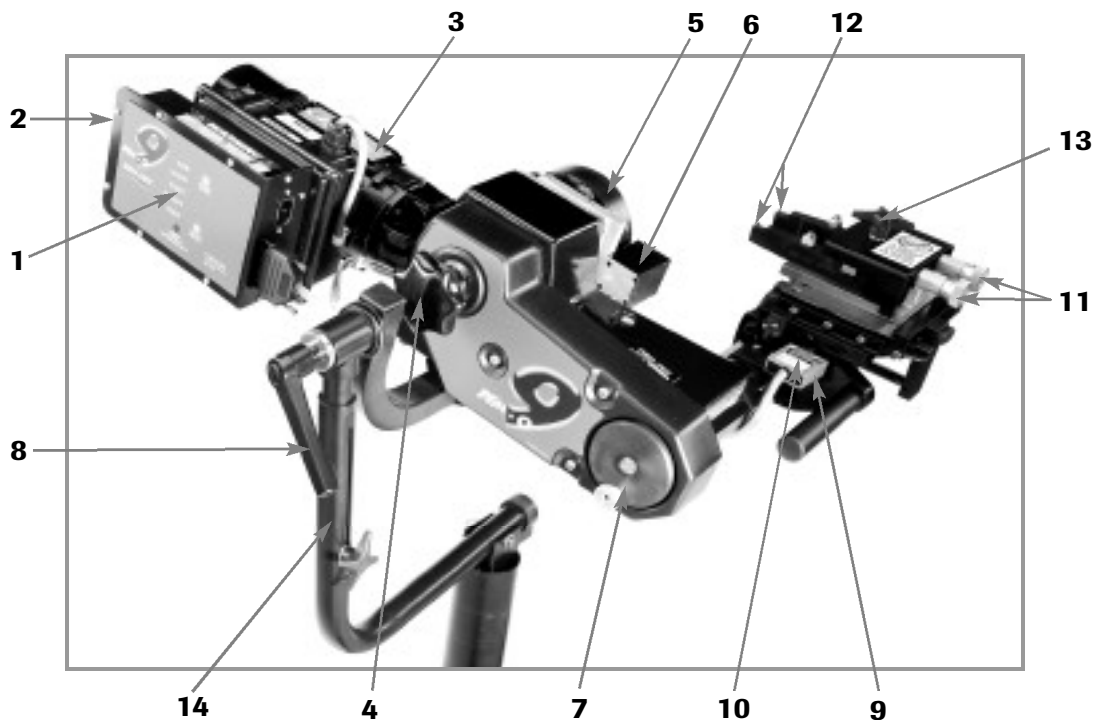

### **COMPONENTS**

- |   |                                       |
|---|---------------------------------------|
| <b>1.</b> PFM 9.0 Computer Box          | <b>8.</b> Trolley Handle              |
| <b>2.</b> On/Off Switch                 | <b>9.</b> Automatic Shut-off Switch   |
| <b>3.</b> .95 hp Motor                  | <b>10.</b> Automatic Shut-off Cam     |
| <b>4.</b> Mounting Knob                 | <b>11.</b> Cut Depth Adjustment Dials |
| <b>5.</b> Adjuster Flange               | <b>12.</b> Cutting Tips/Inserts       |
| <b>6.</b> Adjuster Solenoid             | <b>13.</b> Cut Head Lock Knob         |
| <b>7.</b> Feed Knob/Feed Engage Plunger | <b>14.</b> Trolley                    |



# Setting Up a New Lathe

Before you begin setting up, check contents against the parts diagram enclosed in the lathe package. If you are missing any parts, call Pro-Cut immediately.

## ASSEMBLE THE TROLLEY

Open the trolley box and check contents against the parts diagram. If you are missing any parts, call Pro-Cut immediately. Proceed with assembly, following the instructions enclosed in the box.

## MOUNT THE LATHE TO THE TROLLEY

Once the trolley is assembled you will need to mount the lathe to the trolley. The easiest way to do this is to remove the mount arm from the trolley and assemble it onto the body of the lathe.

- 1) Remove the trolley handle (37-461) and thrust washer (37-251) and slide the support arm assembly (50-303 and 50-304) off of the pivot (50-315).
- 2) Remove the lathe body from the shipping pallet and turn it upside down. Align the holes in the lower arm (50-304) with the bosses on the bottom of the lathe. The welded nut on the upper arm (50-303) should be in line with the drawbar knob (50-651). Bolt the lower arm (50-304) to the lathe using the two M10 bolts (35-246) and two washers (37-108).
- 3) Flip the lathe over with the drawbar knob facing away from you. Position the serrated lock washer (37-620) on the nose of the pivot (50-315). Using proper back protection and lifting procedures, lift the lathe and lathe support arm (50-303 and 50-304) and fit them onto the pivot (50-315). Slide the thrust washer (37-351) over the threaded portion of the trolley handle (37-461) and slide through the pivot (50-315). Tighten up the trolley handle (37-461).



Connect the trolley arm to the lathe first, then mount the arm/lathe combination to the trolley.



## **Vehicle Preparation**

**NOTE:** Remember to mark rotors before removing them so you can be sure they are returned to the same positions on the hub.

Before lifting the vehicle, the front wheels should be straight and the parking brake should be off, with the transmission in neutral.

- 1)** Raise the vehicle according to the lift manufacturer's instructions. Raise until the wheel hub is about belt level.
- 2)** If any other wheel service is required, it should be performed before machining the rotors. Check wheel bearings for damage or excessive play.
- 3)** Remove the wheels. Remove the brake calipers and suspend them out of the way of moving parts such as half shafts and CV joints.
- 4)** If the rotor is free on the hub, mark and remove it in order to assess the mating surface. Use a Scotch-Brite™ type wheel on a die grinder to remove rust or debris. Clean all material from the mounting area.
- 5)** The rotor on the side of the vehicle that is not to be machined should be marked and removed if it is free on the hub. Match marking the rotors to the hub is very important.
- 6)** Use a micrometer to measure rotor thickness and determine how much material may be removed from the rotor. Visually inspect for deep rust or grooves. This inspection will help determine the depth of the cut.



## Where to Start – Driver or Passenger Side?

The Pro-Cut PFM 9.0 machines both front and rear rotors. The lathe's operations do not change at all in the rear of the vehicle.

It is important to start on the proper side. The Pro-Cut mounts directly to the hub of the vehicle. With the lathe right-side up the cutting head is to the right of the hub as you face the vehicle wheel well. When machining a rotor the cutting head is most often positioned where the caliper rides. On a vehicle where the calipers ride in front of the hub, always start on the passenger side. If the caliper rides to the rear of the hub, begin on the driver's side.

When you flip the lathe to machine the opposite side of the vehicle, no difficult adjustments are required since they were made in the right-side up position.

**cutting  
edge**



### MEASURE TWICE, CUT ONCE

Vehicle preparation is critical. If you pay close attention to details before mounting the lathe you can be sure the brake job will go smoothly and quickly. Be especially sensitive to excessive bearing play (which should be addressed before mounting the lathe) or unusual rotor wear (which may require a deep initial cut to avoid multiple passes).



Lathe in right-side-up position. Note that adjustments to cutting head are simpler in this position.



Lathe in upside-down position. You will need to flip the lathe over into this position to machine one side of the vehicle.



## Lathe Preparation

**NOTE:** Use only Pro-Cut Cutting Tips (50-742). Although other tips will fit the machine, only Pro-Cut tips have been specifically engineered in tandem with the Pro-Cut lathe. Using a non-Pro-Cut tip may compromise lathe performance and result in poor surface finish.



### CHECK CUTTING TIPS

Before mounting the lathe check the cutting tips and make sure they are ready for use. The cutting tips are one of the most critical components of the machine. It is vital that they are Pro-Cut brand tips in good condition and properly mounted. Each cutting tip has three corners which may be used. The correctly installed tip is wider on the top and has a groove, or dots, facing up. A tip mounted upside down will produce a surface finish that looks like a record.

**NOTE:** The lathe has a powerful .95 hp motor which requires 20 amp service. All extension cords must be at least 12 gauge and less than 25 feet; drop light cords are not recommended.

You should get at least 7 cuts per corner. However, tip life is affected by variables such as rust or ridges. In order to determine when to rotate tips, monitor rotor finish. If the rotor finish begins to look inconsistent or feels rough to the touch, tips should be rotated. Tips that are chipped or cracked should never be used.

Be sure that the tip pocket is clean before positioning the tip. Any foreign material pinched under the tip will cause problems.

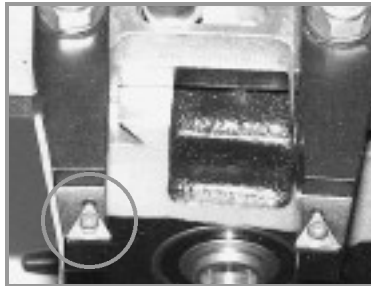

This is the premium Pro-Cut tip (50-742). When the tip is mounted correctly, the chip breaker faces up.



## Machining Rotors: The 4/9.0 Solution

Using the PFM 9.0 is simple. In just 4 steps over 9 minutes any tech can perform top-quality brake work. We call it the 4/9.0 Solution.

- **Step 1: MOUNT THE ADAPTER** (2 minutes)
- **Step 2: SET UP THE LATHE** (2 minutes)
- **Step 3: ADJUST FOR LATERAL RUNOUT** (1 minute)
- **Step 4: MAKE THE CUT** (4 minutes)

The 4/9.0 Solution — 4 steps over just 9 minutes to perform top-quality brake work. If these steps are followed properly on each brake job, the Pro-Cut PFM 9.0 will operate accurately and efficiently.



Step 1 of the 4/9.0 Solution:  
Technician mounts an adapter to the hub.

### Step 1: MOUNT THE ADAPTER (2 minutes)

The first step is to choose the proper adapter. Most passenger cars require either the four (50-687) or five lug (50-688) Direct Fit® adapter. Some larger passenger cars and smaller trucks use the 50-695 adapter. For most trucks and vans, use the larger adapter (50-691). This fits 5, 6, 7, and 8-lug vehicles. (See the complete adapter guide on page 20).

Once you've selected the correct adapter, try each bolt pattern until you find the one that fits the vehicle evenly. When possible, use the nuts provided with the machine. Hand tighten nuts. Do not use impact wrenches to mount adapters. Nuts should be hand-tightened to 25–30 ft. lbs. Excess torque will damage the adapter.

Some 4-wheel-drive vehicles require that you remove the cap from the locking hub. Some also require the use of a spacer (30-791 or 50-246). If the adapter doesn't fit flush and square, use the spacer. Sometimes the holes in the spacer are not needed as the entire bolt pattern will fit in the center of the spacer.

**WARNING:** The adapters are made of cast iron, not aluminum or steel like wheels. They are not designed to withstand the use of impact tools. **DO NOT USE IMPACT GUNS TO ATTACH THESE ADAPTERS.** Twenty to thirty ft.-lbs. applied by hand is plenty to secure the adapter to the vehicle. **DO NOT USE IMPACT WRENCHES TO TIGHTEN LUG NUTS.** Excess torque applied with an impact wrench will damage the adapters. Warranty does not cover this misuse.



**The 4/9.0 Solution, cont.**

**Step 2: SET UP THE LATHE** (2 minutes)

**a. Mount the lathe to the adapter**

Move the cutting head out so that the tips will not strike the rotor as you mount the lathe.

Next, roll the machine into place and match it up with the adapter. Note that the trolley moves up and down to accommodate different heights. The small dowel pin on the face of the adapter will fit into either of the two holes on the runout adjustment flange. Turn the mounting knob to thread the center axle of the lathe with the adapter, securely connecting the lathe to the vehicle.

**NOTE:** It is very important that the machine be mounted smoothly onto the adapter without prying or forcing. Take the time to align the machine properly in order to avoid damage to the runout adjustment flange. The large mounting knob will tighten very easily when the machine is properly aligned. Tighten it snugly.



Step 2 of the 4/9.0 Solution: technician mounts the lathe to the adapter.

**b. Position the lathe for cutting**

Loosen the trolley handle so that the machine is free to rotate. Rotate the machine so that the cutting head is in a position where there is clearance to make the cut. Be sure to check the back side of the rotor for obstacles. Make sure there will be clearance for the chip silencer as well.

**c. Position cutting head and set shut-off cam**

Notice that there are several mounting holes in the slide plate that can be used to lock the cutting head. The cutting head assembly can be secured into any one of the holes. It is a good idea to clean out these holes as well as the dovetail and plate surfaces when you change cutting head position, as they can easily fill up with metal chips. Use

**cutting  
edge**



**SECURING THE  
CUTTING HEAD**

Vibration is the root cause of most surface finish problems. Be sure the cutting head is securely locked in place with the back tight against the dovetail. Tight connections here reduce the chance of vibration.



the T-handle 6mm allen wrench to remove the securing screw and center the head so the cutting arms will straddle the rotor.

It is **critical** that you pull the tool holder plate back into the dovetail so that it is square as you tighten the securing screw. You can use one hand to push the cutting head firmly back into the dovetail as you tighten the set screw with your other hand. **If the tool holder is not squarely and firmly pressed into the dovetail, a poor surface finish will result.**

**NOTE:** The Pro-Cut will mount right-side up on one side and upside down on the other. Always start right-side up; this way, when you proceed to the other side of the vehicle, the offset of the cutting head will already be set, with the cutting head firmly in the dovetail. Never attempt to move the cutting head laterally with the lathe upside down.

Next you will set the shut-off cam. Crank the feed knob until the tips clear the outside edge of the rotor. Loosen the cam screw and slide the cam back until it contacts the automatic shut-off switch plunger. Tighten the cam screw. The cam will press the shut-off switch when the tips clear the rotor. This allows for unattended operation.

**WARNING:** If the tool holder is not squarely and firmly pressed into the dovetail, a poor surface finish will result.

**WARNING:** Never attempt to move the cutting head laterally with the lathe upside down.

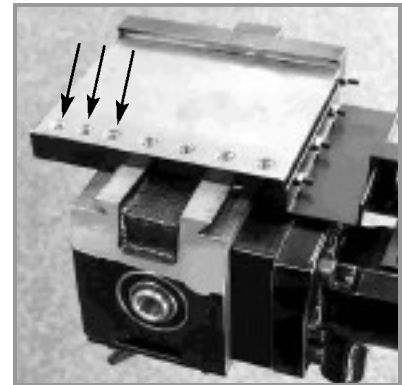

The cutting head connects to the cutting plate (50-499) by a bolt. The bolt threads through one of tapped holes in the plate. Different holes in the plate allow the cutting head to be set for any vehicle.

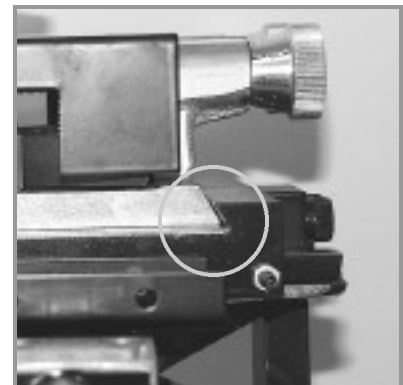

Note the dovetail at the back of the cutting head. This dovetail must be tight. Be sure to pull back on the cutting head as you secure the mounting bolt.



**The 4/9.0 Solution, cont.****Step 3: ADJUST FOR LATERAL RUNOUT** (1 minute)

You must adjust for lateral runout to eliminate wobble (runout) from the machine before cutting. This procedure ensures the resulting machined rotor will have minimal runout after cutting. The PFM 9.0 has been calibrated to reduce runout to less than 0.002" as measured on the rotor.



Detail of the PFM 9.0 computer box.

**a. Compensate for runout**

The PFM 9.0 compensates for runout automatically. With the machine mounted and running, press the **START** button and hold for 2 seconds. This will initiate the measurement/adjustment process. The "adjusting" light will illuminate, and the adjuster solenoid will change the angle (at the adjustment flange) until the lathe rotates with minimal runout. This procedure will usually take between 10 to 60 seconds. Total adjustment time depends on a number of factors including initial runout and the resistance in the hub. Average adjustment time is less than a minute.

When the machine is done adjusting, one or more lights will give feedback on the status of the lathe.

When either green light is lit, the machine is ready to cut. If both green lights are on, the machine has reduced the runout to less than 0.001". If only one green light is on, the machine had more difficulty adjusting for runout due to any number of factors, but eventually reached a level of runout that is acceptable (less than 0.003" runout). You may try again as the machine may be able to reach the optimum level of runout with additional attempts.

If the **TRY AGAIN** light is illuminated, the machine has failed to fully adjust for runout. This difficulty could be due to looseness of fittings, irregular runout, damage to wheel bearings or other components, or other factors. The best procedure is to loosen the machine from the adapter, rotate the wheel 180 degrees, and attach the machine again. Make sure that the machine is adequately supported by the trolley. Run the adjustment procedure and the machine will again adjust for runout. If



TRY AGAIN appears repeatedly, there is most often a problem with the vehicle. You should dismount the machine and check for a damaged wheel bearing or CV joint. Such problems will have to be addressed before machining is possible.

If the machine seems to be having excessive difficulty in adjusting for lateral runout, consult the **Troubleshooting** section on page 18.

#### Step 4: MAKE THE CUT (4 minutes)

- 1) Loosen the clamp knob on top of the cutting head.
- 2) Turn cut-depth knobs counter-clockwise until the tips can clear both sides of the rotor. Turn on the lathe. Crank the cutting head forward to the middle of the braking surface of the rotor.
- 3) Start with the inside (behind the rotor) tool arm. Turn the depth knob clockwise (tighten) until the tool tip just barely makes contact with the rotor surface. You can listen for the contact. Next move the outside tool arm in until it also makes contact.
- 4) Now, advance the cutting head in towards the center of the rotor. Be careful not to crank the cutting arms into the "hat" of the rotor.
- 5) When you are at the inside edge of the pad contact surface, you may adjust for depth. Each line on the knob moves the cutting tip 0.002". Cut at least 0.004" on each side with each pass. The maximum depth is 0.015" on each side.
- 6) Now that you have adjusted for depth, tighten the clamp knob (over the cutting arms). This must be tight to minimize vibration. Place the chip deflector/silencer over the cutting tips. This silencer is very important, and it should be used on every rotor to prevent vibration.

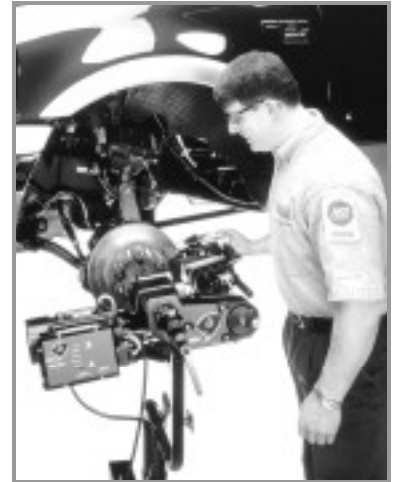

Technician sets cut depth.

**WARNING:** It is extremely important not to touch the hat of the rotor with the left tool holder. This will damage or break the tool holder plate. This type of damage is not covered by the warranty.



**The 4/9.0 Solution, cont.**

**cutting  
edge**



If the rotor is severely worn it may be necessary to machine away the ridges on the inside and outside of the pad contact area before machining the pad contact surface.

**7)** Press the feed engage crank handle to engage the automatic feed. The machine will shut off when the cut is finished. The cut will take two to four minutes depending on the size of the rotor.

**8)** When you are finished cutting, manually crank the cutting head out beyond the rotor for lathe removal. Loosen the mounting knob and remove the lathe from the adapter. Be careful not to bump either the rotor or the wheel well as you dismount the lathe. Take special care not to bump the tips into the rotor.

**9)** Before removing the adapter, measure and record the lateral runout on the rotor. Also measure and record the thickness to ensure that it is above “machine to” specification. When you have finished your measurements, be sure to clear the hub area of any brake chips, dust, or debris.

**10)** If the rotor is loose on the hub, secure the rotor with a lug nut before machining the other side. If you remove the rotor after machining, you must mark it so it can be remounted in the correct (same) position.

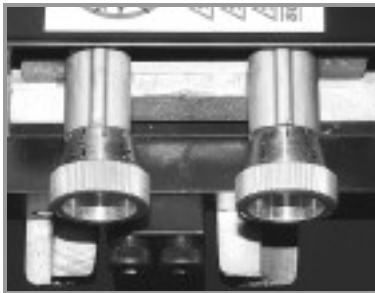

Turn the dials to advance the cutting head. Each line on the dial indicates 0.002”.

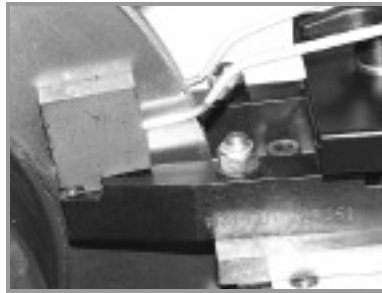

The chip deflector rides over the cutting arms as shown above. The chip deflector should be used every time.



Move the cutting head by turning the knob shown above.



## Machining the Opposite Side

Be sure the auto cut-off switch is not still engaged from your first cut.

- 1) Loosen the trolley handle and rotate the machine into the upside-down position.
- 2) The procedure for cutting in the upside-down position is the same, though fewer steps are needed since all settings have already been made. The lathe mounts in the same manner. Often, the shut-off switch will still be depressed from the previous cut, so the machine will not turn on until you move the cutting head. The cutting arms will also still be advanced in from the last cut, so be sure to loosen the clamp knob and spread the arms before feeding the head towards the center of the rotor. Measuring and adjusting for runout is exactly the same as in the upright position. The entire cutting process is also the same, right down to the silencer clip which mounts upside down in the exact same position.

**WARNING:** Advancing the cutting head towards the hat of the rotor requires even more care when upside down. Be careful not to bump the hat of the rotor!

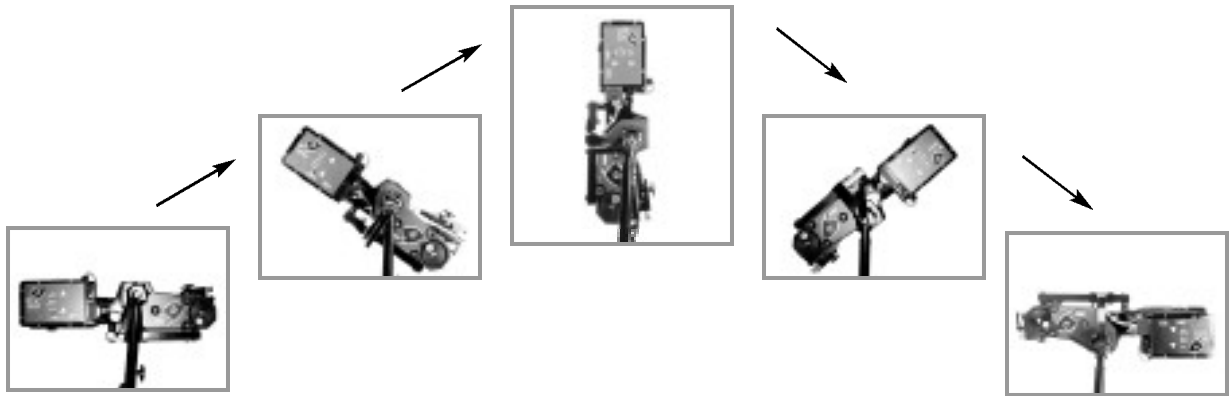

After loosening the trolley handle, the lathe can be flipped over to machine the opposite side of the vehicle.



## **Vehicle Reassembly**

Be sure to use a TorkStik when remounting the wheel. Excess or uneven torquing of lug nuts will ruin any brake job.

When machining on both sides is complete, clean any dust or debris from the finished rotor with 150 grit sandpaper and then a damp rag. Cast iron dust left on the rotor can cause brake squeal. All surfaces should be cleaned of chips and dust. Special care should be used in making sure that ABS sensors are free of debris. Reassemble the brakes and wheels to the manufacturer's specifications.

## **Maintenance**

The Pro-Cut lathe is simple and rugged. With just a few maintenance tips you can ensure a long and profitable life for your machine.

### **DAILY MAINTENANCE**

Check tool tip edges. If there are chips or dings, turn or replace the tip. Be sure they are right-side up so that the groove or dots are visible. Each tip has three cutting points. When worn out, replace them. When changing tool tips, clean the threads and put a spot of Vaseline® (or thick grease) in the bottom of the screw hole before tightening the tool bit screw. The Vaseline will stop chips from accumulating in the hole and rusting in place. If chips do rust in place they can often be dislodged by poking a needle through the hole.

Clean the tool holder plate (50-499), taking special care that there are not chips or dirt wedged in the dovetail.

Check the electrical connections and cord for cuts in insulation or wear.



## WEEKLY MAINTENANCE

Lubricate the cut depth adjustment wedge threads with a thin coat of light machine oil.

Check the tool holder plate for damage. Slide a 0.003" feeler gauge between the tool holder plate and the base plate (50-499). If it can be inserted freely your tool holder plate is damaged. A damaged tool holder plate will often cause a vibration during the cut. This will leave a herringbone pattern on the rotor.

Check the tool holder for lateral play. Lateral play often causes ridges and matching grooves when a rotor is resurfaced. To check for lateral play, grab the tool arm assembly and try and rotate it diagonally. There should be no motion. If there is motion, you will need to tighten the gib (see the section below).

## Troubleshooting: Assuring a Smooth Finish

The Pro-Cut PFM 9.0 should provide a smooth surface finish on every cut, free of chatter, tone, or roughness. If your machine leaves a substandard, "chatter" or rough finish, you need to find the problem. Below are the common sources of poor surface finish and ways to remedy the problem.

Brake performance is dependent upon rotor surface finish. The Pro-Cut lathe has been designed to give you a superior surface finish on any rotor as long as proper maintenance is followed.

Minimized vibration during machining is the key to high-quality surface finish. It is critical that all contact points between the rotor and the lathe are secure. Specifically, the connections between lathe and adapter; the slide plate and the lathe; the cutting head and the plate; and the tips and the tool holders. Looseness in any of these areas will compromise lathe performance and surface finish.



### CHECK CUTTING TIPS

The cutting tips must be right-side up. Dots face up. The cutting tips should not have chips or dings in the surface of the points. Do not take cuts of less than 4 thousandths of an inch unless absolutely necessary. Cuts of 4 to 10 thousandths will provide the best surface finish and the longest tip life.

### MAKE SURE CUTTING HEAD IS SNUG

On each brake job, the technician must center the cutting head for that particular vehicle, using one of the holes on the slide plate. Once the head is centered, it is vital that the technician use one hand to push the head firmly and squarely back into the dovetail on the slide plate while using the other hand to tighten the allen bolt that secures the head. Failure to do this will result in chatter.



The chip deflector reduces vibration and must be used on **every** cut.

### USE THE CHIP DEFLECTOR

The chip deflector included with the lathe is a critical component. The pressure of its pads provides a great deal of dampening that reduces the chance of vibration while cutting. The chip deflector must be used on every cut to ensure proper finish. New chip deflectors can be purchased directly from Pro-Cut.

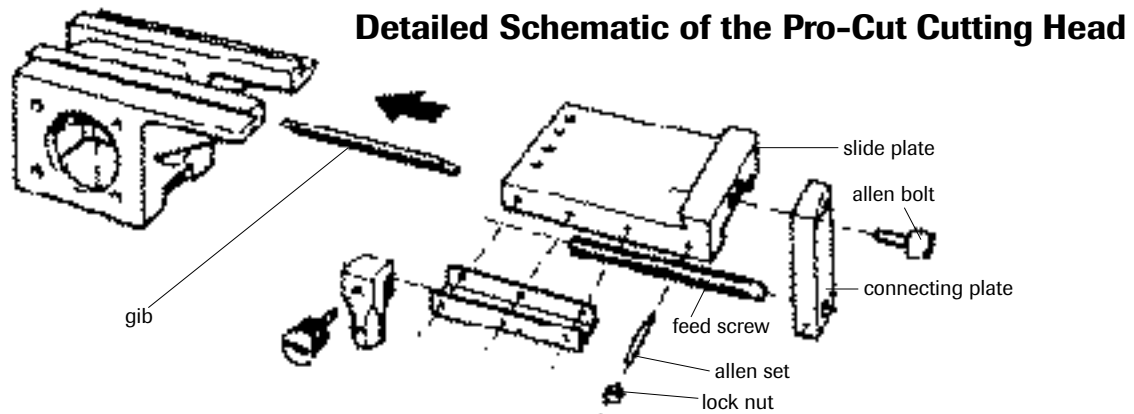

### CHECK FOR BENT TOOL HOLDER PLATE

The tool holder plate holds the cutting arms. It will bend or break if the technician accidentally runs the cutting arms into the hat of the rotor while the lathe is turning.

To diagnose whether or not the plate is bent, place it on the slide plate and try to slide a 0.003" feeler gauge between the two plates. If the feeler gauge can be inserted freely, the tool holder plate is bent and needs to be replaced.

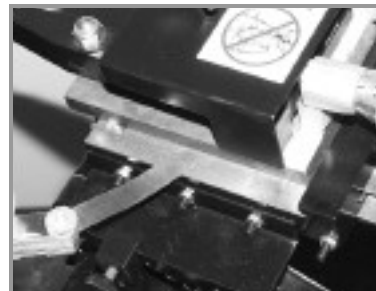

Checking the tool holder plate for damage. The toolholder plate is bent if a 0.003" feeler gauge can fit between the cutting head and the mounting plate. This condition leads to compromised surface finish.

### TIGHTEN THE GIB

Poor finish quality can be the result of a loose cutting head. As wear occurs between the slide plate and the box it rides on, you must take up the slack. You do this by tightening the moveable wedge we call the "gib." (50-464)

If the cutting head can be moved from side to side at all, it should be tightened. To adjust the gib, first loosen all four set screws (with 2.5mm allen wrench) by freeing the 7mm lock nut and loosening the allen set screw. Remove the plate and gib completely, and clean the contact surfaces. Locate the plate in the middle of the rail with the gib between the plate the the rail. Be sure the 4 notches of the gib are aligned the catch the allen set screws as they're tightened through the plate. Tighten each allen set screw until you feel it snug against the gib. Hold light pressure with the allen wrench as you lock the screw down with the 7mm lock nut. After tightening each nut, slide the plate to make sure there is no binding. **When the gib is adjusted properly, the plate will have some resistance as it slides, with no lateral movement possible.**

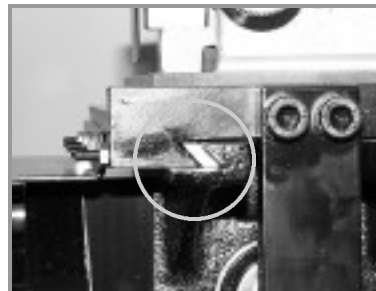

Detail of the gib that rides between the gear box and cutting plate.

To reattach the feed block, move the slide plate as far forward as it can travel, and wind the feed block in to meet it. This ensures that the feed block will be properly centered. Wind the head back out and the machine is ready for use.



## Troubleshooting: Lateral Runout Adjustment

The PFM 9.0 can be calibrated to adjust to tighter or looser standards.

If the machine is having difficulty adjusting for lateral runout, first assess the vehicle being serviced. If lateral movement is rough or uneven due to damaged vehicle components, these components must be repaired or replaced before rotors are machined. It is also important that the machine be supported by the trolley during adjustment.

If the problem seems to be with the brake lathe itself, you may re-calibrate the machine according to the procedure outlined below.

If the machine displays a green light when there is still excessive runout in the system, you should tighten the calibration.

If the machine does not display the green light even when runout has been minimized, you should loosen the calibration.

### CALIBRATION PROCEDURE

The PFM 9.0 is calibrated with an “acceptance number.” To **tighten the calibration**, you need to **lower the acceptance number**. To **loosen the calibration**, you need to **raise the acceptance number**. Here’s how to raise or lower the acceptance number:

- 1) With the brake lathe plugged in **but not turning**, push RESET and wait for the READY TO START light to be illuminated.
- 2) With the READY TO START light illuminated, press and hold the CALIBRATION button (located just below the lights) until the ADJUSTING light illuminates, then release the CALIBRATION button.
- 3) Now the machine is displaying the acceptance number using a simple binary code. Each flashing light represents a number. The lowest green light is worth 1, the next light up is 2, the next light is 4, the next light is 8 and the top (READY TO START) light is 16. So if the lowest light only was lit, the acceptance number would be one. If every light was lit, the acceptance number would be 31 (1+2+4+8+16). Add the values of the lights which are lit. Generally this should total 18-22.



- 4) To raise the acceptance number (loosen the calibration), press the **START** button once. To lower the acceptance number (tighten the calibration), press the **CALIBRATION** button once. The acceptance number will change in increments of two. After raising or lowering (you'll see the binary code change), hit the **RESET** button to save the change.
- 5) Once you have raised or lowered the acceptance number by two and hit **RESET**, test the machine to ensure that the problem has been solved. You may need to repeat the procedure once or twice to fully solve the problem.

If you have any difficulty or questions about executing this procedure, call Pro-Cut.

## Reading the Binary Codes

Higher binary codes will yield a wider acceptance range. Lower binary codes result in tighter acceptance bands.

When the machine displays the binary codes, add the total of all the flashing lights.

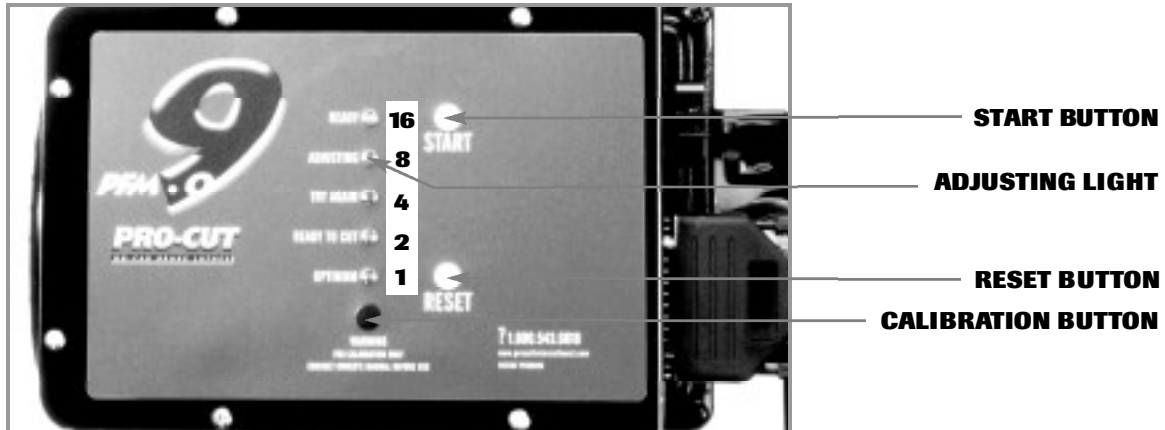

The illustration above shows binary values for each light. For example, when the 2nd and 4th lights are blinking, the total binary value is 10 (2 for light #2, plus 8 for light #4).



## Adapter Guide

---



### 50-687 4-Hole DIRECT FIT® Adapter

This adapter fits 4-lug cars except certain Subarus. (See 50-691 below for older Subarus).  
**Basic Package / Master Package**

### 50-688 5-Hole DIRECT FIT® Adapter

This adapter fits small 5-lug vehicles. Most 5-lug cars (except Full size) and a few light trucks can be machined using this adapter. **Basic Package / Master Package**



### 50-595 GM/Dakota DIRECT FIT® Adapter

This adapter has 5-lug patterns for large cars and small 5-lug trucks. It also has the 6-lug Dodge Dakota pattern. **Master Package**

### 50-691 4x4 DIRECT FIT® Adapter

This adapter has 5-, 6-, 7-, and 8-lug patterns to fit most trucks up to one ton. (On some vehicles, the 30-791 spacer must be used with this adapter.) Dual wheel trucks and larger Ford trucks require optional adapters listed below. NOTE: The large Subaru “4 on 140mm” pattern is also on this adapter. **Master Package**



## Optional Adapters

---



### 50-683 Heavy Duty Ford DIRECT FIT® Adapter

This optional adapter is necessary for machining many 8-lug Ford Trucks and Vans.

### 50-935rev4 Dual Wheel Pickup DIRECT FIT® Adapter

This optional adapter is necessary for machining front rotors on dual wheel trucks. Dual wheel Fords also require a cutting head extension. (Note: the PFM 9.0 also requires 50-046 to machine duallies.)



### 50-696 Rover Adapter

This optional adapter is necessary for machining Land Rovers and Range Rovers with the large “5 on 165mm” bolt pattern.



# PFM 9.0 Parts Diagram

## 50-238 Cutting Head

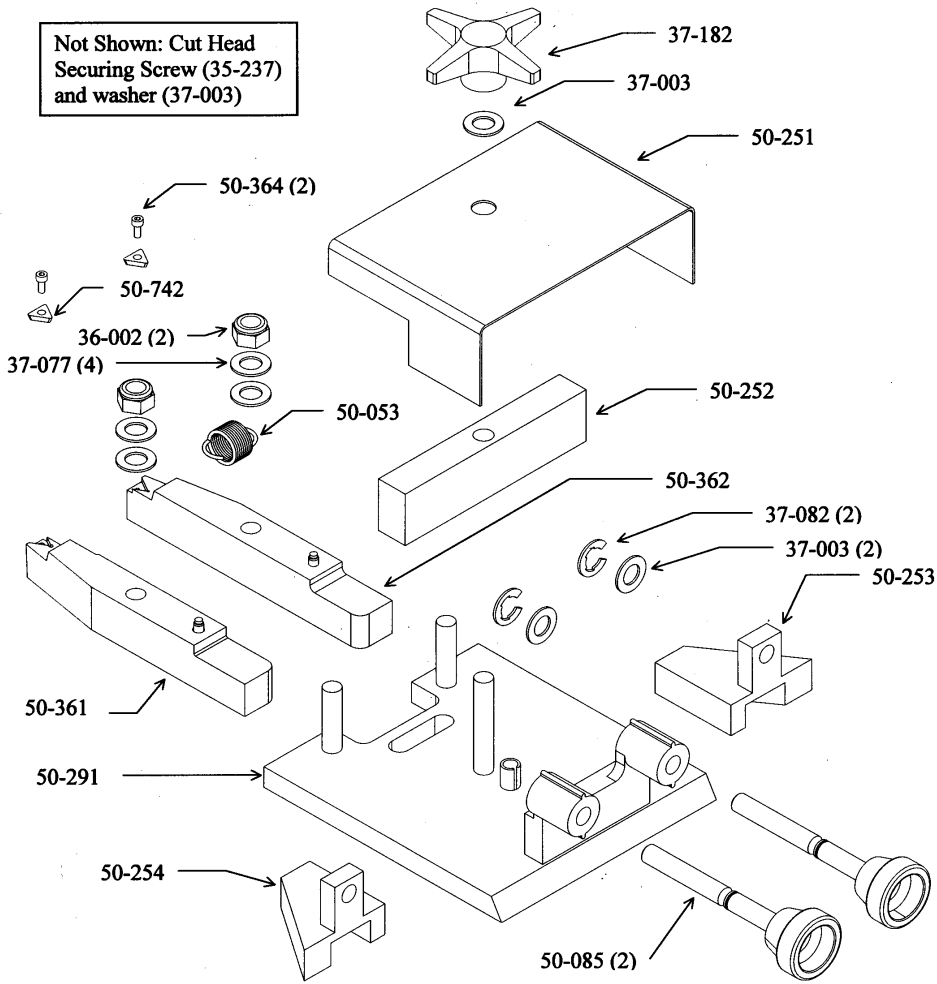

## Bevel Gear Box

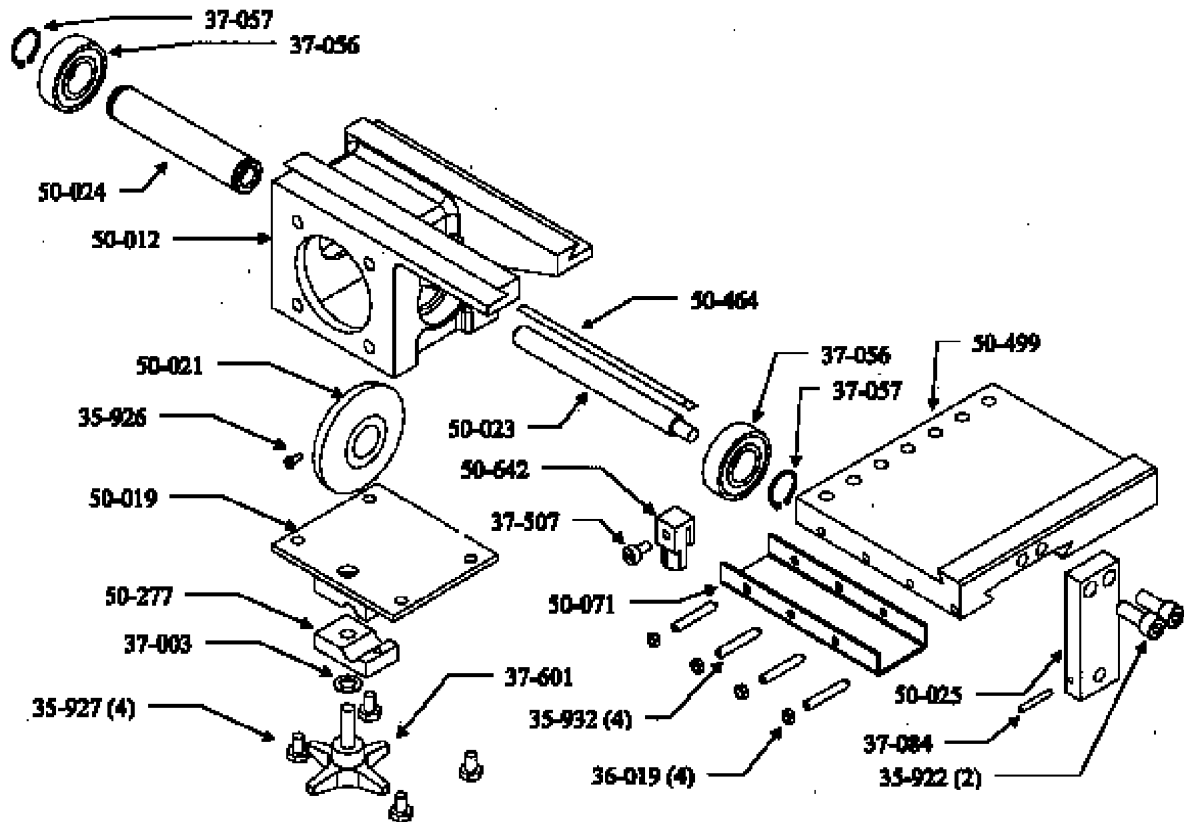

### PFM 9.0 Lathe Body

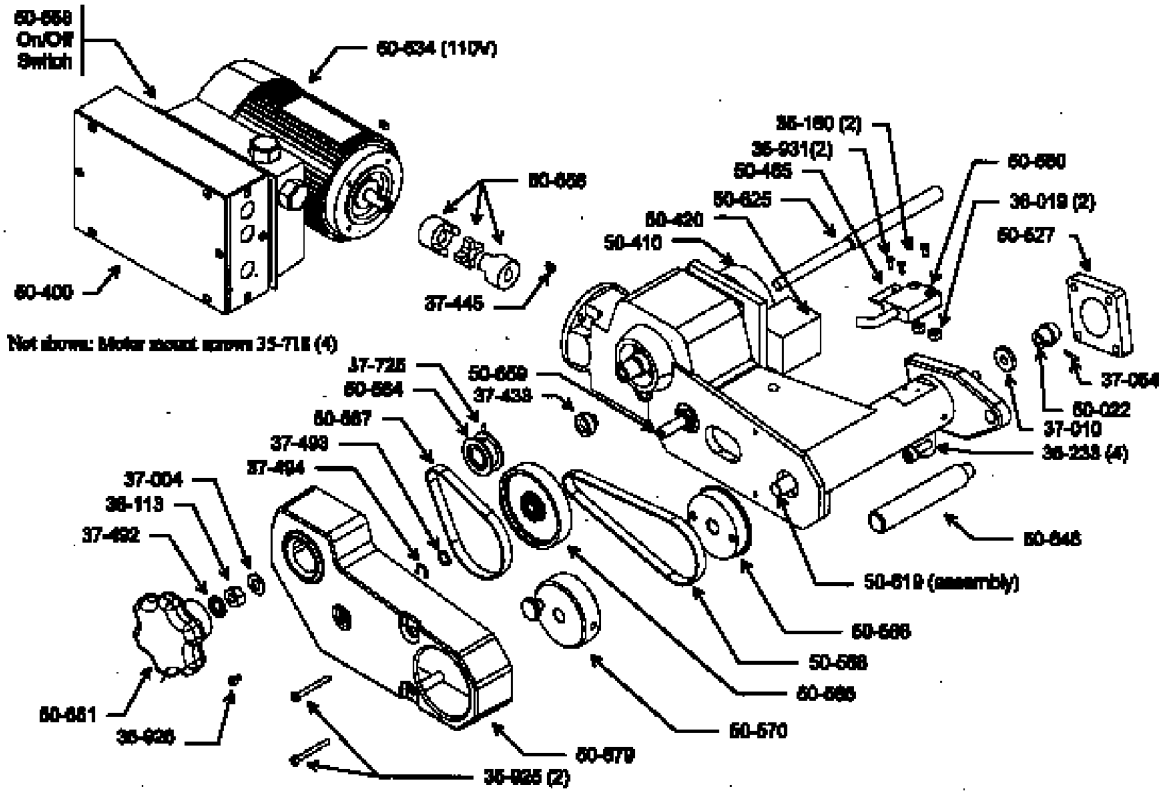

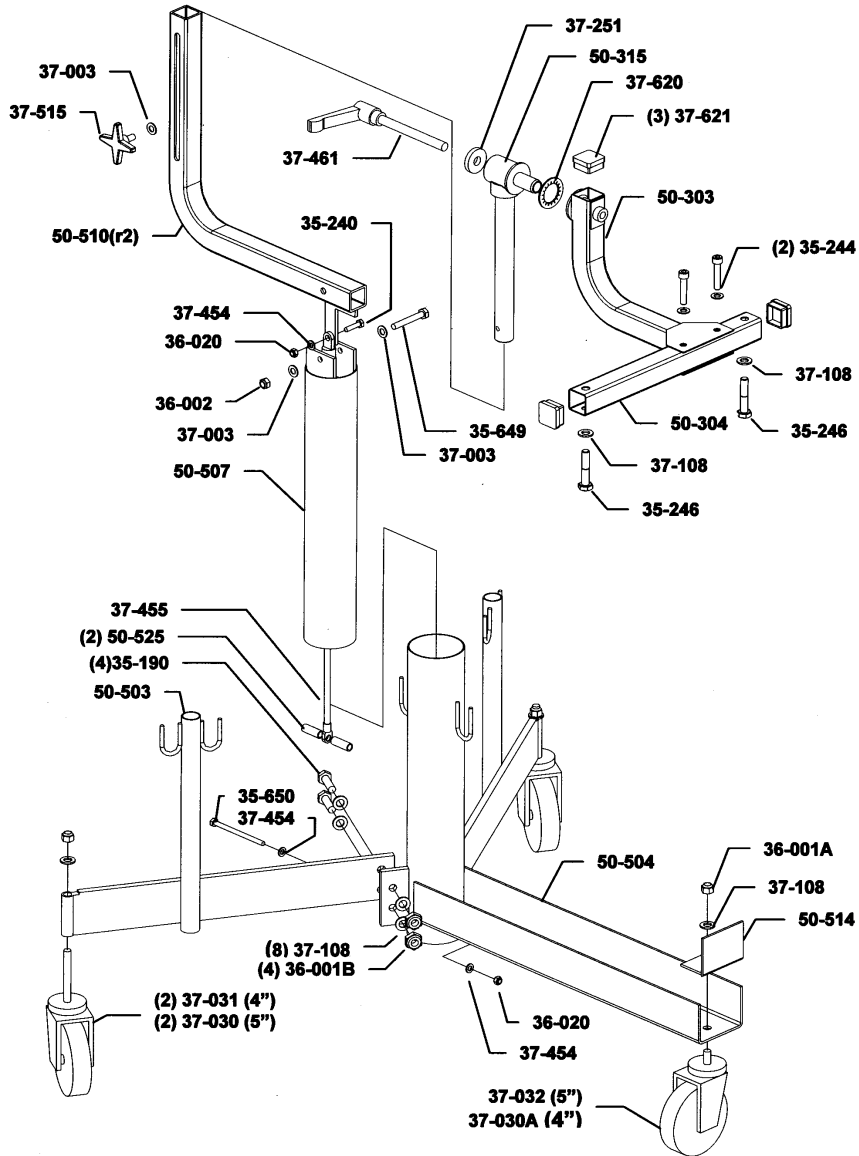

# Pro-Cut Trolley





**PRO-CUT INTERNATIONAL** 10 Technology Drive, #4, West Lebanon, NH 03784

 800.543.6618  
603.298.5200

 603.298.8404

 [info@procutinternational.com](mailto:info@procutinternational.com) [www.procutinternational.com](http://www.procutinternational.com)